



Mechanical Seal Guidelines for Wastewater Treatment

Introduction

Wastewater treatment plants have two basic purposes. First, they duplicate and speed up the purification process that takes place naturally in rivers, lakes and streams. Their second purpose is to reduce toxic contaminants that can interfere with natural processes. The importance of these plants grows with expansion of our population and the subsequent increase in wastewater volume. When the wastewater volume gets too high, this puts the natural system out of balance, and denies oxygen to the water and the fish and plants in the water. With wastewater treatment plants performing that purification, we can keep pollution levels down and keep oxygen at the proper levels to sustain a healthy aquatic ecosystem.

As federal, state and local controls over water quality increase, these wastewater treatment plants become more complex and operating costs rise. Flowserve sealing systems can offer significant savings in the wastewater treatment industry including:

1. Reduced environmental contamination
2. Lower power requirements
3. Reduced downtime by increased mean time between planned maintenance (MTBPM)
4. Reduced maintenance costs with the implementation of mechanical seals due to their:
 - ease of installation
 - long, trouble-free life
 - designed repairability
 - low cost repair program
 - elimination of packing adjustment costs



These guidelines reference the latest technology in cartridge, slurry, and split seals. The ISC2 Series and SL Series cartridge seal designs reduce maintenance, training, and downtime costs. They allow for impeller adjustment by permitting axial shaft movement without pump disassembly. All are designed for a wide variety of services, ranging from water and wastewater, to chemical and light duty slurry service. Cartridge mounted SL Series slurry seal designs provide rugged cross sections for tough applications downstream in the solids treatment area of a wastewater treatment plant.

Flowserve offers split seals for applications where downtime and equipment disassembly are critical. The PSS III is a split seal for pumps that provides an ease of installation unmatched in the industry. Used with a SEB (Solids Excluder Bushing) or split flow reducer, flush rates can be limited to as little as 5 gph per inch of shaft on most applications.

As an introduction to the wastewater treatment industry, short descriptions of the various processes involved in a wastewater treatment plant are attached. They are followed by corresponding sections of the selection guide, which

summarize recommendations for seal type, materials of construction, and environmental controls to obtain the maximum benefit from the use of the latest sealing technology. Alternative designs are shown to allow for the most cost effective selection based on plant practice, availability of an external flush, difficult equipment tear down, etc. These seal recommendations should be considered as guidelines denoting the preferred designs for the applications listed. In many cases other Flowserve seals may be suitable depending on application requirements and customer preferences. If you are unsure of the suitability of a recommendation for a particular application, contact your Flowserve Representative for assistance.

Equal in importance to proper seal selection is the training of engineering, maintenance, and production personnel in proper installation, operation, and maintenance procedures. Flowserve offers on-site and off-site training to assist in implementing a successful sealing program.

Seal Descriptions

Seals and information shown represent standard configurations of popular seals for the Wastewater Treatment Industry. Other configurations, sizes, and products are available, consult your Flowserve Representative for assistance.

PSS III

A balanced, radially split end face mechanical seal that has seal faces, gaskets, and setting devices unitized into two semi-cartridge components. Collar and gland assemblies have built-in axial and radial setting clips that simplify and ensure installation accuracy. Outside mounted configuration with product located on the seal face OD Standard flush port in the gland. Springs and pins isolated from the product. Positive drive mechanisms are used on seal faces and collar for all product types. Flexible stator design and radial clearances tolerate up to 1.52mm (0.060") total indicated run-out. Wear indicator pins permit visual check of seal setting to estimate face wear and expected run time. Included installation kit provides tools and extra hardware. Standard repair kits available for onsite repair. Material options and operating limits are as follows:

| | |
|--------------------|--|
| Seal Faces: | Carbon versus Aluminum Oxide, Carbon versus Direct Sintered Silicon Carbide, or Reaction Bonded Silicon Carbide versus Direct Sintered Silicon Carbide |
| Metallurgy: | AISI 316 gland and collar with Alloy C-276 springs and set screws |
| Secondary Seals: | Fluoroelastomer, EPR, or TFE-Propylene |
| Maximum Pressure: | full vacuum to 30 bar (450 psi) |
| Temperature Range: | -18° C to 121° C (0° F to 250° F) |
| Sizes: | 38 mm to 152 mm (1.500" to 6.000") for larger sizes use the PSSL |

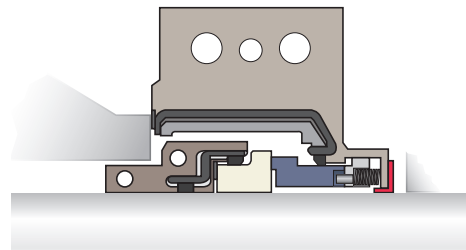

ISC2

Cartridge mounted, hydraulically balanced single and dual seals available in O-ring pusher and metal bellow non-pusher designs. The O-ring pusher design features Alloy C-276 springs that are isolated outside of the product and located in the non-rotating component of the seal. The non-pusher metal bellow design features Alloy C-276 bellows in the rotating component of the seal providing a self-cleaning effect while maintaining excellent seal face loading without hanging up due to solids build-up. The use of patented thermal management technology through thermally conductive and mechanically compliant graphite material dramatically improves seal face heat transfer allowing the seal to run cooler and tolerate dry running events. Material options and operating conditions are as follows:

| | |
|--------------------|--|
| Seal Faces: | Premium Resin Carbon vs. Sintered Silicon Carbide Sintered Silicon Carbide vs. Sintered Silicon Carbide Premium Resin Carbon vs. Tungsten Carbide Tungsten Carbide vs. Sintered Silicon Carbide |
| Metallurgy: | 316 Stainless Steel, Alloy C-276, Alloy 20, Titanium |
| Secondary Seals: | Fluoroelastomer, Perfluoroelastomer, EPDM, TFE-Propylene |
| Maximum Pressure: | Pusher seal 0 to 20.6 bar (300 psig) Metal bellows seal 0 to 13.8 bar (200 psig) |
| Temperature Range: | -40 to 204°C (-40 to 400°F) |
| Sizes: | Pusher seal 25 to 200 mm (1.000" to 8.000") Metal bellows seal 25 to 95 mm (1.000" to 3.750") |

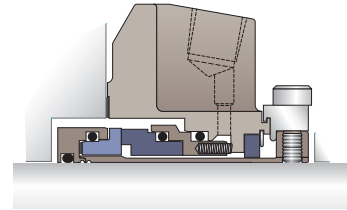

ISC2 single pusher

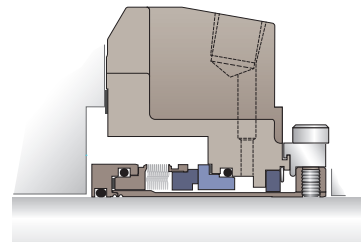

ISC2 single metal bellows

See FSD243 for more information on the ISC2 Series

SLC

Designed to operate without a flush to increase plant efficiency, reduce operating costs and eliminate product dilution. The SLC incorporates a unique non-clogging cone spring design that increases seal reliability. A self-contained single cartridge slurry seal designed to operate in tough slurry. Clamp collar drive provides maximum axial holding force without galling the sleeve. This seal is capable of handling up to 60% solid by weight where Slurry Particle Hardness is at 9 MOH or below. Material options and operating conditions are as follows:

| | |
|--------------------|---|
| Seal Faces: | Silicon Carbide (standard) Tungsten Carbide (optional) |
| Metallurgy: | Hardened, high chrome iron (standard) CD-4MCuN or other alloys (optional) |
| Secondary Seals: | Fluoroelastomer, EPR, or TFE- Propylene |
| Maximum Pressure: | 20.7 bar (300 psi) |
| Temperature Range: | -18° C to 77° C (0° F to 170° F) without water quench -18° to 110° C (0° F to 230° F) with water quench (contact your Flowserve Representative for details) |
| Sizes: | 35 mm to 220 mm (1.35" to 8.661") |

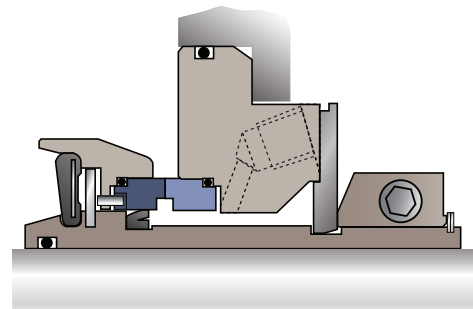

Other materials also available.

See FSD120 for more information on the SLC

SLM Series

A family of self contained cartridge seals designed for reliable operation in the majority of slurry services. Engineered to operate with no outside flush liquid to eliminate product dilution, increase plant efficiency and reduce operating costs. Line-on-line hydraulically balanced faces and the flexibly mounted stator are better able to tolerate shaft deflection and perpendicularity alignment. These seals are capable of handling up to 40% solids by weight where Slurry Particle Hardness is at 9 MOH or below. Available in single and dual configurations. Material options and operating limits are as follows:

Seal Faces: Sintered Silicon Carbide (standard)
 Reaction Bonded Silicon Carbide (optional)
 Tungsten Carbide (optional)

Metallurgy: CD4MCuN , Alloy C-276, Alloy C-276 Springs

Secondary Seals: EPDM, Fluoroelastomer, TFE-propylene

Maximum Pressure: 17.2 bar (250 psi)

Temperature Range: -18° C to 135° C (0° F to 275° F)
 with water quench

Other materials also available

See FSD166 for more information on the SLM Series

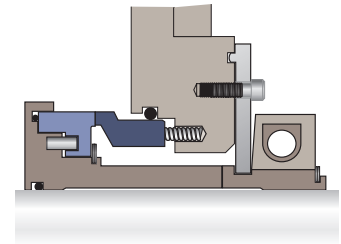

SLM-6000

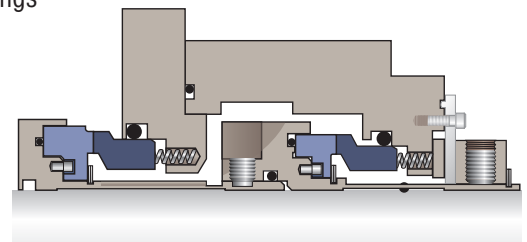

SLM-6200

SEB (Solids Excluder Bushing)

The SEB reduces the amount of flush required and clears solids from the seal chamber. This provides a cleaner operating environment that helps reduce operating costs and improves Mean Time Between Planned Maintenance (MTBPM).

See page 12 and FSD211 for more information on the SEB

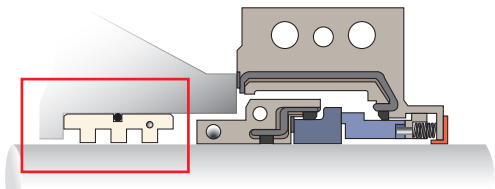

SEB shown with PSS III

Circpac MD

Balanced, segmented circumferential ring seal with hydropad grooves, large bearing pads and a split housing that mounts outside the seal chamber. Hydrodynamic features reduce gas consumption over 10 times less than bushings or labyrinths. Operating window includes pressure up to 100 psi, temperature up to 1100° F, and speed up to 150 fps. Standard radial clearances of up to 0.25" accommodate thermal growth and shaft misalignment. Material options and operating limits are as follows:

Rings: Carbon Graphite

Housing: AISI 316, AISI 410 or Alloy 600

Springs: Alloy 600

Maximum Pressure: vacuum to 6.9 bar (100psi)

Temperature Range: up to 593° C (1100° F)

Maximum Speed: up to 45.7 m/s (150 fps)

Sizes: 35 to 457 mm (1.375" to 18.000")

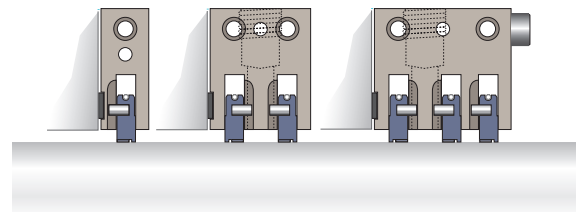

Flush Plans

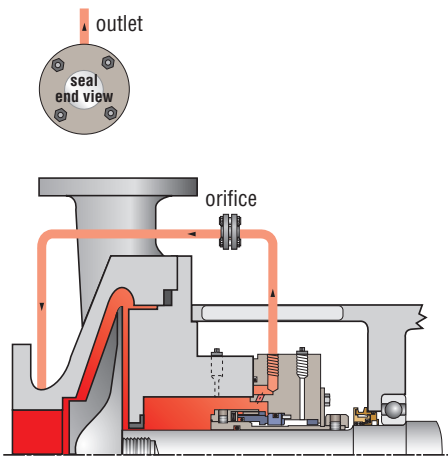

Recirculation to pump suction
Plan 13

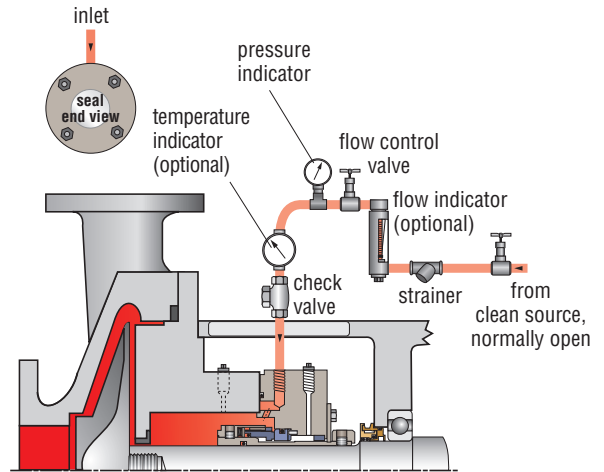

Injection of clean fluid from external source
Plan 32

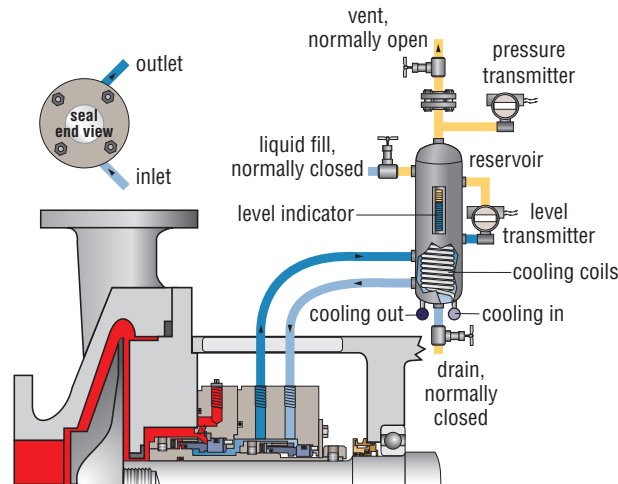

External fluid reservoir, non-pressurized, forced circulation
Plan 52

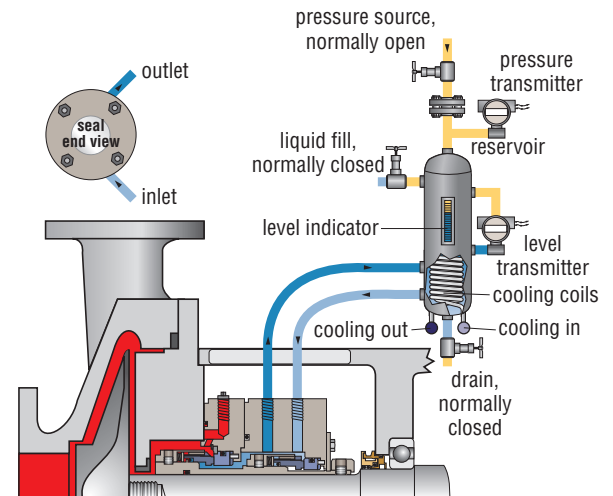

External fluid reservoir, pressurized, forced circulation
Plan 53A

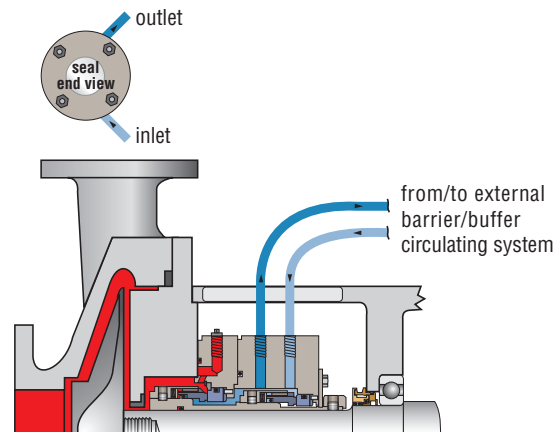

Circulation of clean fluid from an external system
Plan 54 (pressurized) or Plan 55 (non-pressurized)

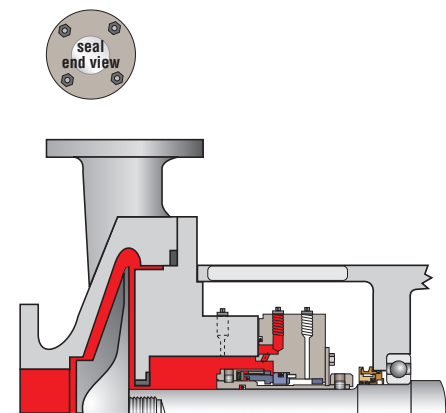

Dead ended, no flush
Plan 02

A facility for handling wastewater normally contains two main sections. The first section processes the wastewater and the other treats the solids that come out of the first plant.

Wastewater Treatment Section Process Summary

In the wastewater processing plant, sewage is put through a series of two or three treatments that remove and concentrate solids and produce disinfected and/or filtered clean water. Primary treatment removes solids in the wastewater by physical means; screening, settling and floating. Secondary treatment uses a biological process to convert the remaining organic material into forms that are separated into solids and a clear liquid, and finishes with chemical and/or UV disinfection of that liquid. Tertiary treatment, including particle filtration and nutrient removal, is used when the final effluent must be extremely clean.

Primary Treatment Area

Wastewater moves through the plant through a combination of pumps and gravity-fed flow. Often, at several lift stations and at the beginning of the plant, the wastewater is pumped up to a higher elevation to begin the gravity-fed process. This is done using horizontal or vertical solids handling dry pit pumps, vertical solids handling wet pit pumps or submersible solids handling pumps, where the solids content is normally less than .1% by volume (2% solids by weight). Similar equipment utilizing vortex or recessed impeller designs is used to move product (still less than 5% solids by weight) from the Primary Treatment area to the Secondary Treatment area or into the Solids Treatment plant. Most of these applications can utilize a single seal, either split or non-split in design. Carbon can be used as one of the seal faces if Plan 32 using recycled effluent is available. If no clean external flush is available, two hard faces are required. Submersible pumps can be located throughout this area of the plant.

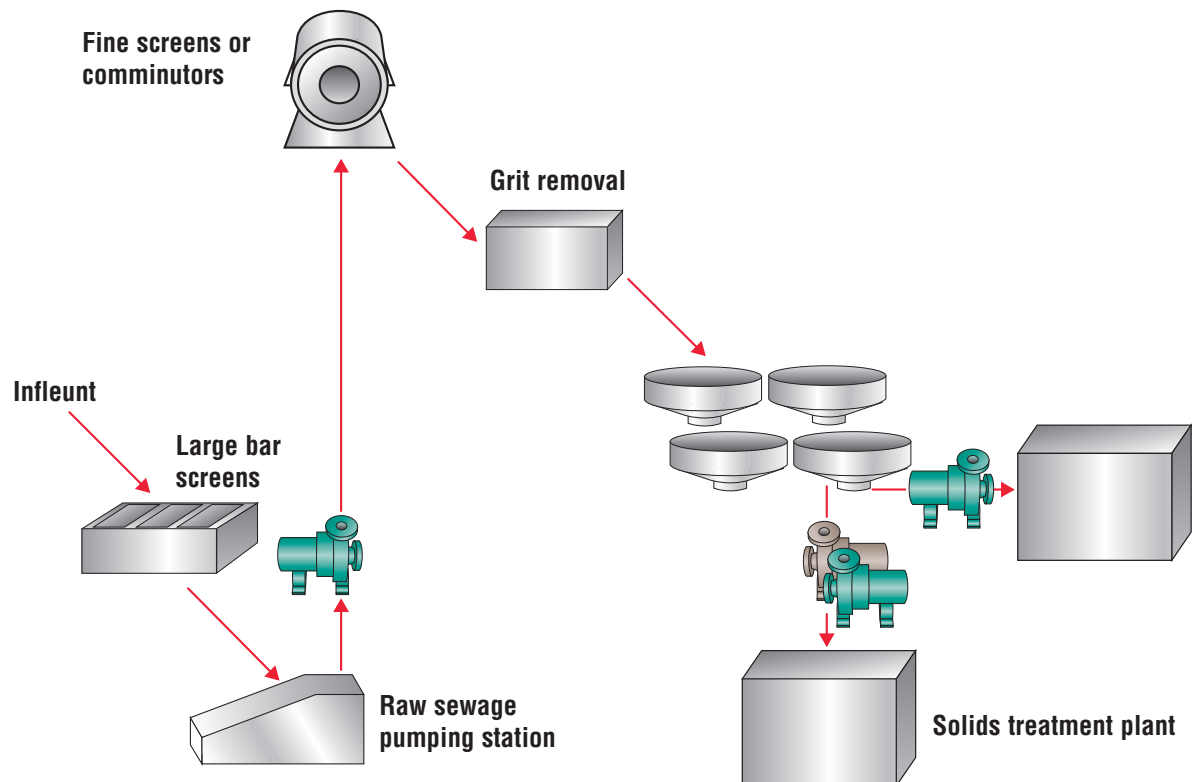

Primary Treatment Application Guide

Raw Sewage Lift Pumps (before grit removal)

Centrifugal (vertical or horizontal) non-clog or recessed impeller pumps. Single seals on vertical pumps without an external flush will require the use of Plan 13 or venting of the seal chamber prior to start of equipment.

Seal Recommendations

Split Seal - **PSS III**

with Plan 32 use Material Code E R 7 E F VV

with Plan 13 or Plan 02 use Material Code E 4 2 E F VV

Note: Plan 13 is strongly recommended on vertical pumps

Non Split Seal - **ISC2**

with Plan 32 use Material Code 5 Z 4 T (pusher seal) or Material Code 9 Z 4 T (metal belows)

with Plan 13 use Material Code 5 Z 4 Z (pusher seal) or Material Code 9 Z 4 Z (metal belows)

Note: Plan 13 is strongly recommended on vertical pumps

Solids Excluder Bushng - **SEB**

with any of the above seals utilizing Plan 32
use Material Code X 8 4 1

Centrifugal Pumps for Sludge and Effluent

Centrifugal (vertical or horizontal) non-clog or recessed impeller pumps. Single seals on vertical pumps without an external flush will require the use of Plan 13 or venting of the seal chamber prior to start of the equipment. Plan 13 may also be used on horizontal pumps.

Seal Recommendations

Split Seal - **PSS III**

with Plan 32 use Material Code E R 7 E F VV

with Plan 13 or Plan 02 use Material Code E 4 2 E F VV

Note: Plan 13 is strongly recommended on vertical pumps

Non Split Seal - **ISC2**

with Plan 32 use Material Code 5 Z 4 T (pusher seal) or Material Code 9 Z 4 T (metal belows)

with Plan 13 use Material Code 5 Z 4 Z (pusher seal) or Material Code 9 Z 4 Z (metal belows)

Note: Plan 13 is strongly recommended on vertical pumps

Solids Excluder Bushng - **SEB**

with any of the above seals utilizing Plan 32
use Material Code X 8 4 1

Slurry Seal - **SLM-6000**

with Plan 02 use Material Code B/E 2 2 B/E P L-AQ L-AQ

Slurry Seal - **SLC**

with Plan 02 use Material Code D Z 5 Z

Slurry Seal - **SLM-6200**

with Plan 52, Plan 53A, or Plan 54/55
use Material Code E 4/R 2 E F VV

Submersible Solids Handling Pumps

Elastomer Bellows Single Spring Seal - **Pac-Seal Type 21/31**

with Plan 32 use Material Code B C F J F

with Plan 02 use Material Code V X F X F

Secondary Treatment Area

The Secondary Treatment Area takes wastewater coming out of the Primary Treatment Area, and moves it through Aeration Tanks, Final Clarifiers & Disinfection. When it enters the Secondary Treatment area, this material still contains solids & dissolved materials. Aeration Tanks provide an environment ideal for microorganisms to break down organic materials and nutrients. Final Clarifiers are used to generate three different products; microorganisms recycled back to the Aeration Tanks, excess microorganisms that are moved to the Solids Treatment Plant, and water that is sent on to Tertiary treatment and/or Disinfection Basin. Submersible pumps can be located throughout this area of the plant.

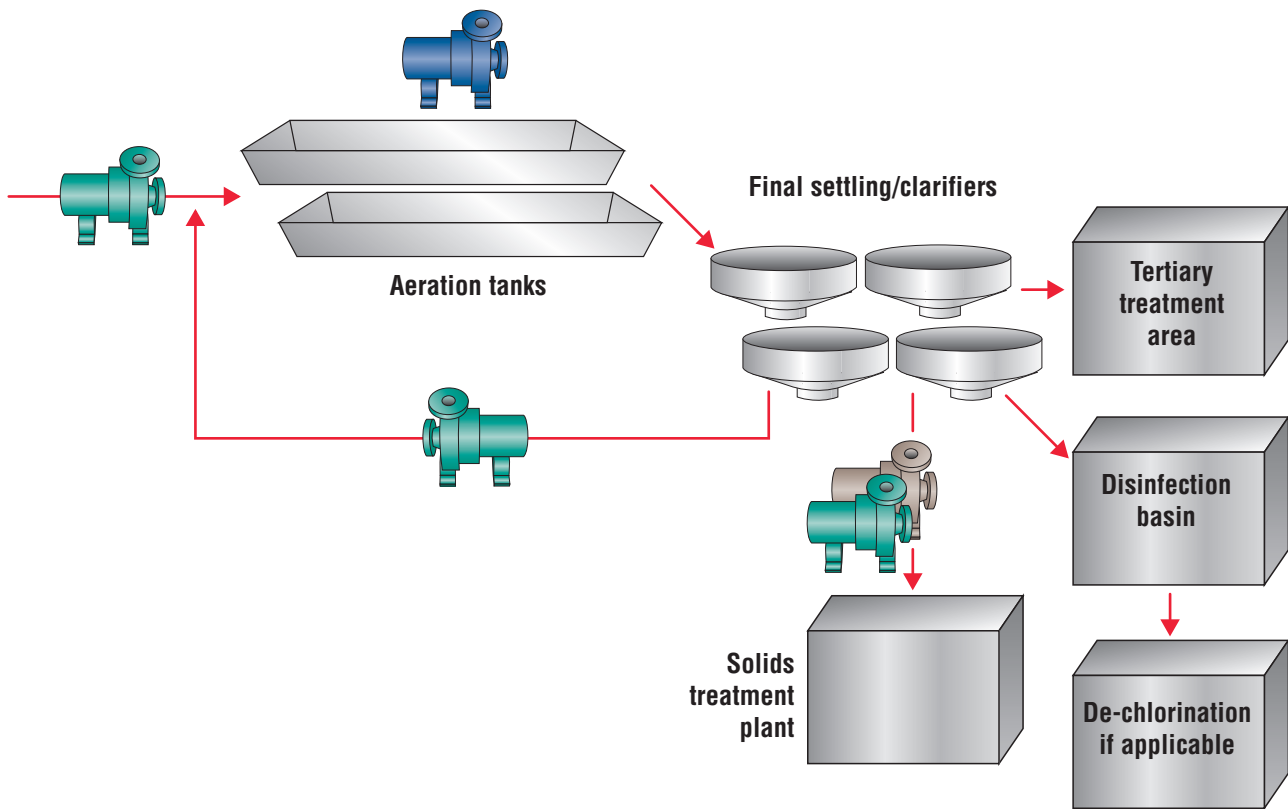

Secondary Treatment Application Guide

Centrifugal Pumps for Sludge & Effluent

Centrifugal (vertical or horizontal) non-clog or recessed impeller pumps. Single seals on vertical pumps without an external flush will require the use of Plan 13 or venting of the seal chamber prior to start of the equipment.

Seal Recommendations

Split Seal - **PSS III**

with Plan 32 use Material Code E R 7 E F VV

with Plan 13 or Plan 02 use Material Code E 4 2 E F VV

Note: Plan 13 is strongly recommended on vertical pumps

Non Split Seal - **ISC2**

with Plan 32 use Material Code 5 Z 4 T (pusher seal) or Material Code 9 Z 4 T (metal belows)

with Plan 13 use Material Code 5 Z 4 Z (pusher seal) or Material Code 9 Z 4 Z (metal belows)

Note: Plan 13 is strongly recommended on vertical pumps

Solids Excluder Bushng - **SEB**

with any of the above seals utilizing Plan 32
use Material Code X 8 4 1

Slurry Seal - **SLM-6000**

with Plan 02 use Material Code B/E 2 2 B/E P L-AQ L-AQ

Slurry Seal - **SLC**

with Plan 02 use Material Code D Z 5 Z

Slurry Seal - **SLM-6200**

with Plan 52, Plan 53A, or Plan 54/55
use Material Code E 4/R 2 E F VV

Fans/Blowers for Aeration

Seal Recommendations

Segmented Circumferential Gas Seal - **Circpac MD**

Single: use Material Code - R9 - E P - V

Multiple: use Material Code - R9 - E P - V

Submersible Solids Handling Pumps

Seal Recommendations

Elastomer Bellows Single Seal - **Pac-Seal Type 21/31**

with Plan 32 use Material Code B C F J F

with Plan 02 use Material Code V X F X F

Tertiary Treatment Area

If local water regulations require it, or if the water is intended for use in irrigation, it may also be passed through filters of sand and crushed coal to remove additional small particles, or treated further to reduce nutrient levels. The clean water that results (clarified effluent) can be pumped back to the plant to be used for clean external flush (Plan 32) or for other purposes.

Solids Treatment Plant Process Summary

In the Solids Treatment Plant, sludge removed from Settling/Clarifiers is thickened using Settling Tanks (Thickeners), Dissolved Air Flotation Thickeners (DAFs), Belt Thickeners and Digesters, along with Presses and/or Centrifuges. As material moves through these processes, the sludge becomes a heavier slurry. As this happens, progressive cavity pumps or positive displacement pumps replace the non-clog (recessed impeller) centrifugal pumps used in earlier stages. Submersible pumps can be located throughout this area of the plant.

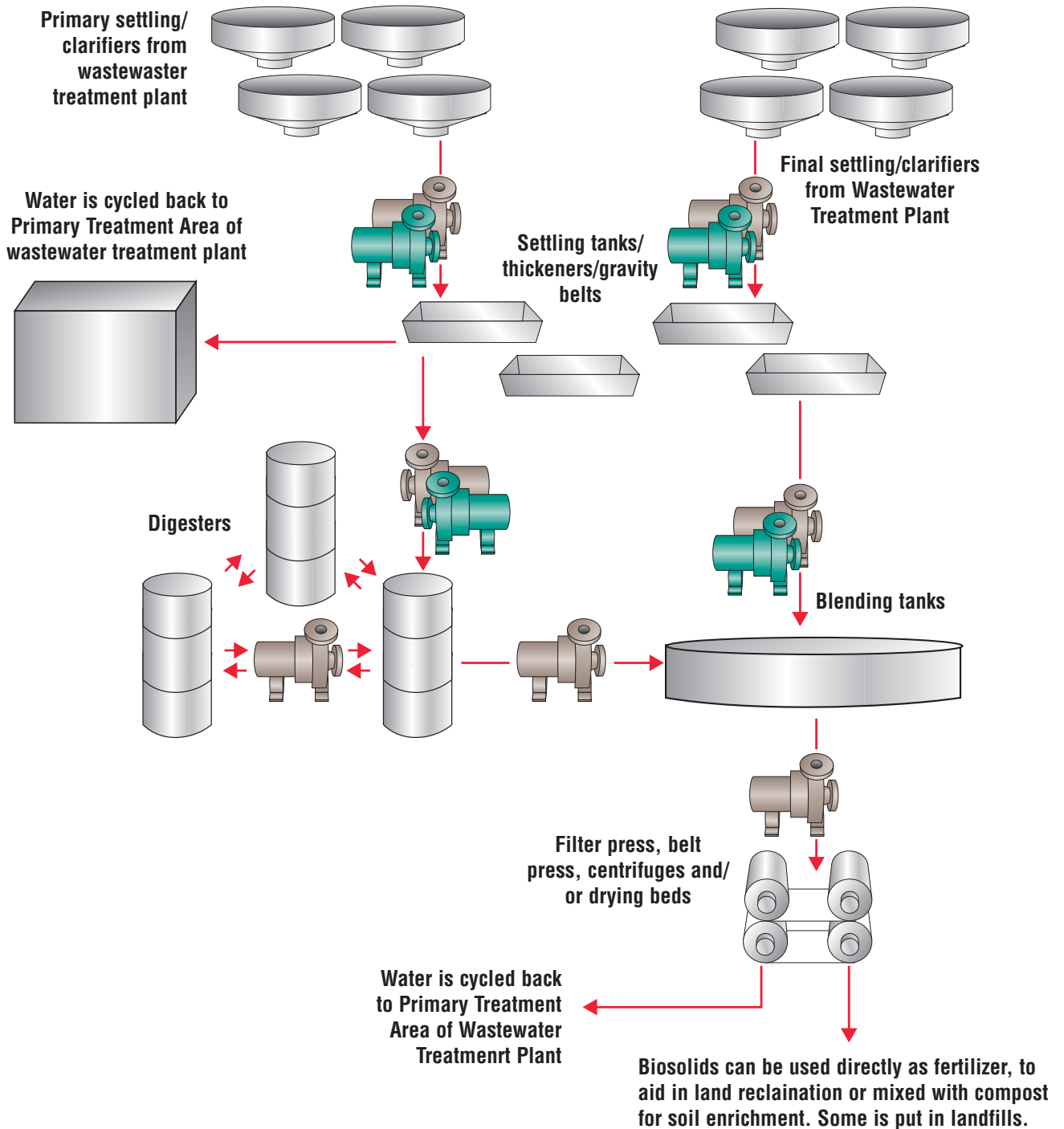

Solids Treatment Plant Process Application Guide

Centrifugal Pumps for Sludge & Effluent

Centrifugal (vertical or horizontal) non-clog or recessed impeller pumps. Single seals on vertical pumps without an external flush will require the use of Plan 13 or venting of the seal chamber prior to start of the equipment.

Seal Recommendations

Split Seal - **PSS III**

With Plan 32 use Material Code E R 7 E F VV

With Plan 13 or Plan 02 use Material Code E 4 2 E F VV

Note: Plan 13 is strongly recommended on vertical pumps

Non Split Seal - **ISC2**

with Plan 32 use Material Code 5 Z 4 T (pusher seal) or Material Code 9 Z 4 T (metal belows)

with Plan 13 use Material Code 5 Z 4 Z (pusher seal) or Material Code 9 Z 4 Z (metal belows)

Note: Plan 13 is strongly recommended on vertical pumps

Solids Excluder Bushng - **SEB**

with any of the above seals utilizing Plan 32 use Material Code X 8 4 1

Slurry Seal - **SLM-6000**

with Plan 02 use Material Code B/E 2 2 B/E P L-AQ L-AQ

Slurry Seal - **SLC**

with Plan 02 use Material Code D Z 5 Z

Slurry Seal - **SLM-6200**

with Plan 52, Plan 53A, or Plan 54/55

use Material Code E 4/R 2 E F VV

Thickened Sludge Pumps & Sludge Feed Pumps

Progressive Cavity or Positive Displacement Pumps.

Seal Recommendations

Split Seal - **PSS II**

with Plan 32 use Material Code E R 7 E F VV

Non Split Seal - **ISC2**

with Plan 32 use Material Code 5 Z 4 T (pusher seal) or Material Code 9 Z 4 T (metal belows)

with Plan 13 use Material Code 5 Z 4 Z (pusher seal) or Material Code 9 Z 4 Z (metal belows)

Note: Plan 13 is strongly recommended on vertical pumps

Solids Excluder Bushng - **SEB**

with the above seal utilizing Plan 32 use Material Code X 8 4 1

Slurry Seal - **SLM-6000**

with Plan 02 use Material Code B/E 2 2 B/E P L-AQ L-AQ

Slurry Seal - **SLM-6200**

with Plan 52, Plan 53, or Plan 54/55 use

Material Code E 4/R 2 E F VV

Digester-Process Pumps

Progressive Cavity or Positive Displacement Pumps

Seal Recommendations

Slurry Seal - **SLM-6000**

with Plan 02 use Material Code B/E 2 2 B/E P L-AQ L-AQ

Slurry Seal - **SLC**

with Plan 02 use Material Code D Z 5 Z

Slurry Seal - **SLM-6200**

with Plan 52, Plan 53A, or Plan 54/55

use Material Code E 4/R 2 E F VV

Split Seal - **PSS III**

with Plan 32 use Material Code E R 7 E F VV

Non Split Seal - **ISC2**

with Plan 32 use Material Code 5 Z 4 Z (pusher seal) or Material Code 9 Z 4 Z (metal belows)

Submersible Solids Handling Pumps

Seal Recommendations

Elastomer Bellows Single Spring Seal - **Pac-Seal Type 21/31**

with API Plan 32 (ANSI Plan 7332) use Material Code B C F J F

with API Plan 02 (ANSI Plan 7302) use Material Code V X F X F

SEB (Solids Excluder Bushing)

Used with a Flowserve seal like the PSS III, the SEB reduces the amount of flush required and clears solids from the seal chamber by redirecting the movement of the solids out of the stuffing box and replaces the solids with clean fluid. Recirculation of fluid also provides cooling to the mechanical seal. Flush rates can be reduced to as little as 0.75 liters/hour for each mm of shaft diameter diameter (5 gallons/hour for each inch of shaft). PTFE construction promotes compatibility with chemical applications. Abrasion resistant PEEK offers longevity in abrasive applications. Large circulating grooves reduce plugging of the solids media within the SEB.

Two designs are offered to maximize performance within even the most confined stuffing boxes.

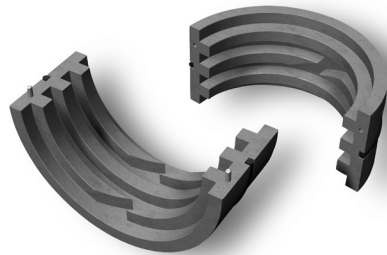

For more information on the SEB, see FSD211

FTA156eng Rev 06-15

To find your local Flowserve representative
and find out more about Flowserve Corporation,
visit www.flowserve.com

Flowserve Corporation has established industry leadership in the design and manufacture of its products. When properly selected, this Flowserve product is designed to perform its intended function safely during its useful life. However, the purchaser or user of Flowserve products should be aware that Flowserve products might be used in numerous applications under a wide variety of industrial service conditions. Although Flowserve can provide general guidelines, it cannot provide specific data and warnings for all possible applications. The purchaser/user must therefore assume the ultimate responsibility for the proper sizing and selection, installation, operation, and maintenance of Flowserve products. The purchaser/user should read and understand the Installation Instructions included with the product, and train its employees and contractors in the safe use of Flowserve products in connection with the specific application.

While the information and specifications contained in this literature are believed to be accurate, they are supplied for informative purposes only and should not be considered certified or as a guarantee of satisfactory results by reliance thereon. Nothing contained herein is to be construed as a warranty or guarantee, express or implied, regarding any matter with respect to this product. Because Flowserve is continually improving and upgrading its product design, the specifications, dimensions and information contained herein are subject to change without notice. Should any question arise concerning these provisions, the purchaser/user should contact Flowserve Corporation at any one of its worldwide operations or offices.

© 2015 Flowserve Corporation

USA and Canada

Kalamazoo, Michigan USA
Telephone: 1 269 381 2650
Telefax: 1 269 382 8726

Europe, Middle East, Africa

Roosendaal, The Netherlands
Telephone: 31 165 581400
Telefax: 31 165 554590

Asia Pacific

Singapore
Telephone: 65 6544 6800
Telefax: 65 6214 0541

Latin America

Mexico City
Telephone: 52 55 5567 7170
Telefax: 52 55 5567 4224